

CARRELLATO R.G.

VERSIONE : 02

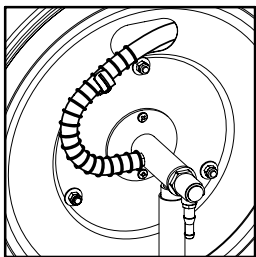

Montaggio tubo facilitato
Easily installable hose

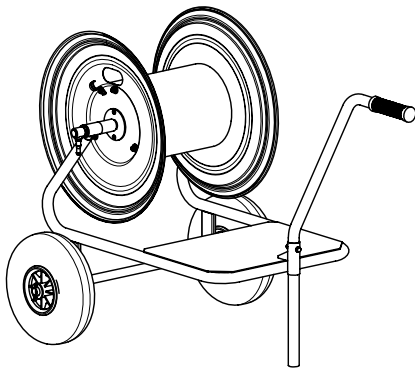
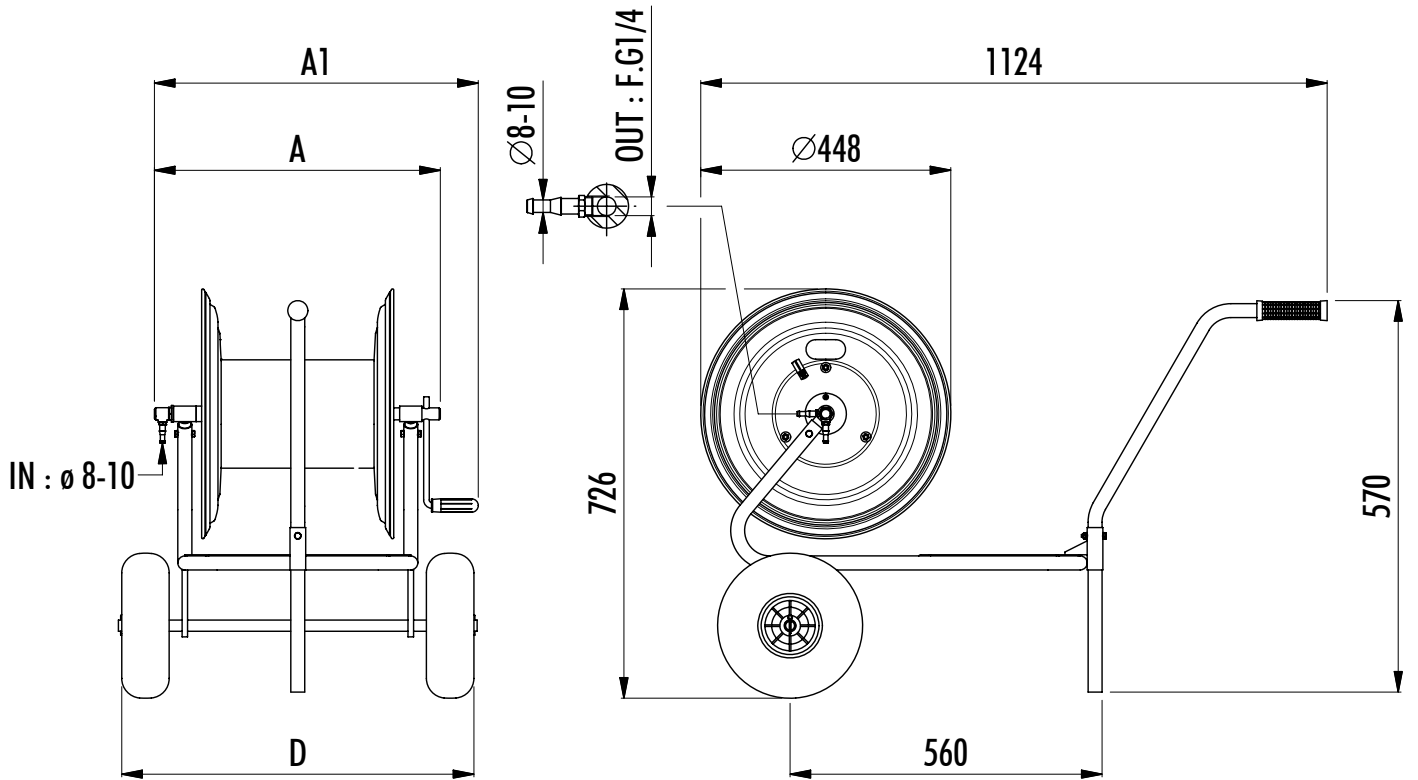
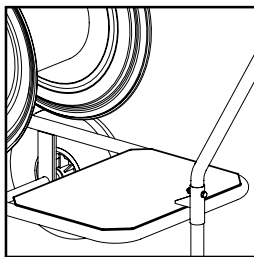

Base per motopompa
Pump set support

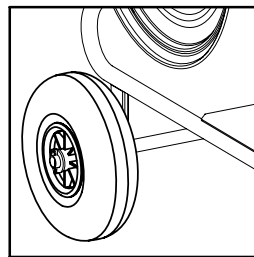

Ruote gonfiabili
Pumpable wheels

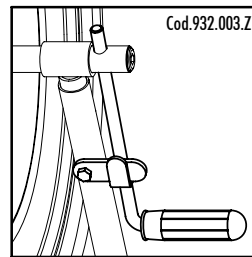

Bloccaggio rullo (optional)
Reel stop (optional)

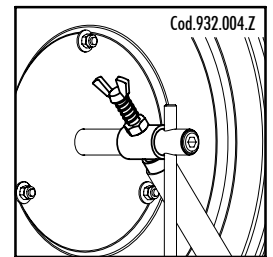

Frizione (optional)
Clutch (optional)

Codice verniciato <i>Code painted</i>	Codice zincato <i>Code galvanized</i>	BAR	Lunghezza e diametro tubo consigliati <i>Recommended hose length and diameter</i>	Dimensioni <i>Dimensions</i>			Metri di tubo riavvolgibili calcolati su diversi diametri esterni in pollici e millimetri <i>Metres of hose, which can be rewinded, calculated on different external diameters in inches and millimeters</i>								Peso <i>Weight</i>	
				A1	A	D	Ø 1/4				Ø 1/2					
							14	15	16	17	18	19	20	21		22
240.050.M	240.050.Z	50	50 m - Ø 10x18	480	410	530	103	90	84	65	65	60	60	45	45	9.3 Kg
240.100.M	240.100.Z	50	100 m - Ø 10x18	580	510	630	172	134	130	109	100	95	77	70	65	11.8 Kg
240.150.M	240.150.Z	50	150 m - Ø 10x18	680	610	730	232	187	175	142	136	110	105	101	95	14.3 Kg