

# CARRELLATO

VERSIONE : 02

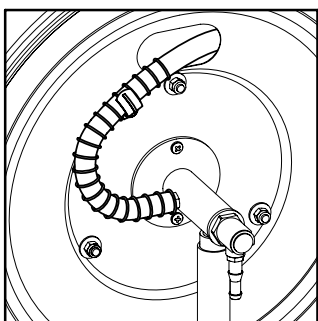

Montaggio tubo facilitato  
Easily installable hose

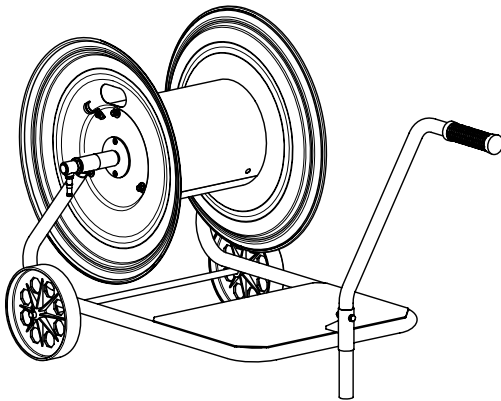
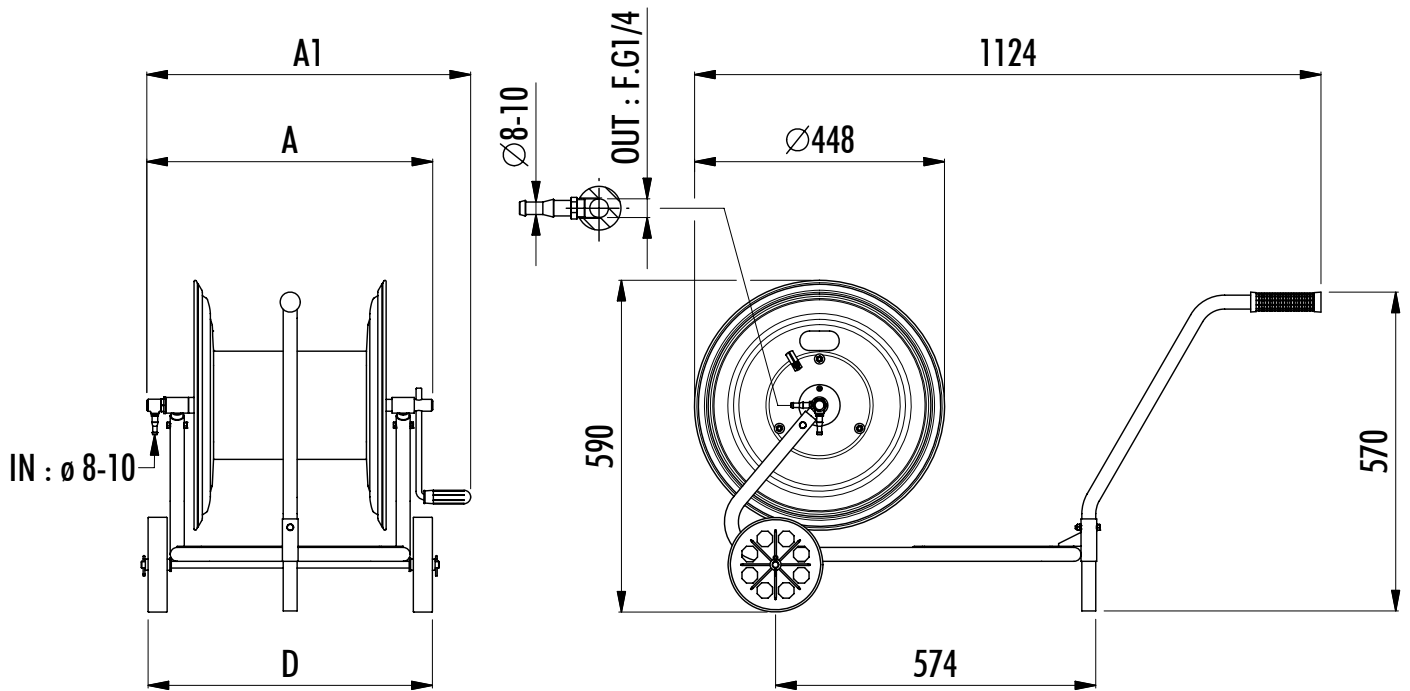
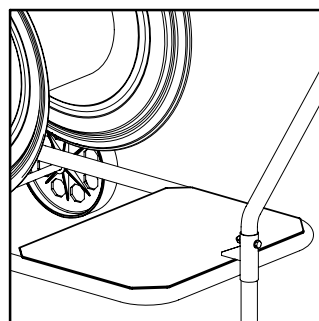

Base per motopompa  
Pump set support

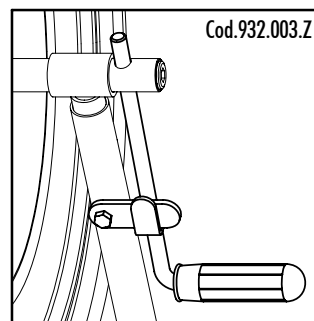

Bloccaggio rullo (optional)  
Reel stop (optional)

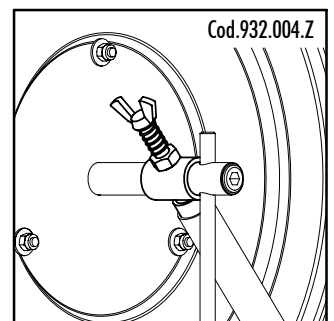

Frizione (optional)  
Clutch (optional)

Codice verniciato Code painted	Codice zincato Code galvanized	BAR	Lunghezza e diametro tubo consigliati Recommended hose length and diameter	Dimensioni Dimensions			Metri di tubo riavvolgibili calcolati su diversi diametri esterni in pollici e millimetri Metres of hose, which can be rewinded, calculated on different external diameters in inches and millimeters								Peso Weight		
				A1	A	D	$\varnothing$ 5/16				$\varnothing$ 3/8					$\varnothing$ 1/2	
							14	15	16	17	18	19	20	21		22	
230.050.M	230.050.Z	50	50 m - $\varnothing$ 10x18	480	410	410	103	90	84	65	65	60	60	45	45	7.3 Kg	
230.100.M	230.100.Z	50	100 m - $\varnothing$ 10x18	580	510	510	172	134	130	109	100	95	77	70	65	9.8 Kg	
230.150.M	230.150.Z	50	150 m - $\varnothing$ 10x18	680	610	610	232	187	175	142	136	110	105	101	95	12.3 Kg	